



Blow Out Preventer

Prevent and control potentially hazardous situations

Blow Out Preventer

- 🌀 Introduction to tool
- 🌀 Features
- 🌀 Benefits
- 🌀 Specs
- 🌀 Contact Information
- 🌀 WOS Overview & Locations



BOP Overview

- Blowout preventers are a critical component of well control systems, and their proper functioning is crucial to prevent and mitigate the consequences of well blowouts.
- The WOS blow out preventer is safety equipment designed to prevent uncontrolled flow of formation fluids during completion and production operations. WOS owned, inspected and 3rd party certified can be trusted with the last line of defense during a well kick preventing a well control issue.
- WOS follows the strict requirements for the use, maintenance, and testing of blowout preventers to ensure the safety of oil and gas drilling operations.

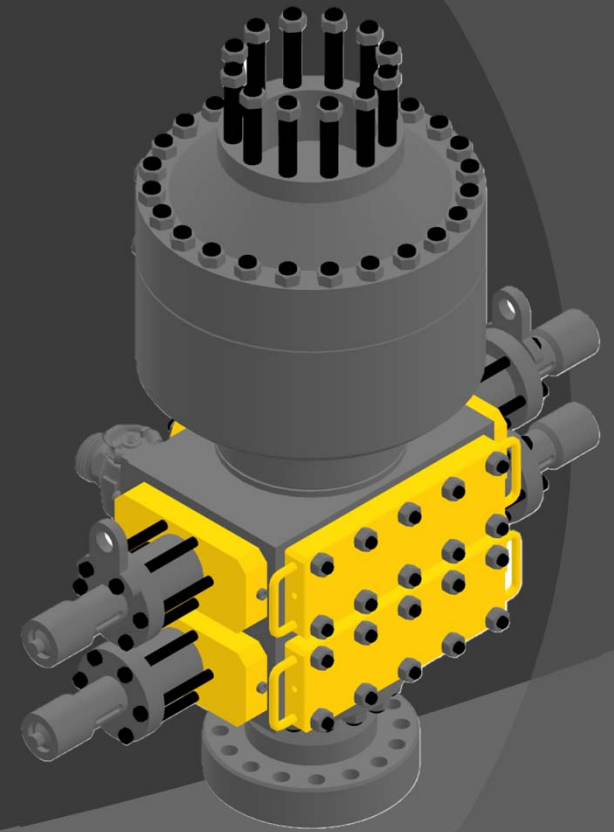

Features

- ④ 5,000 psi rated
- ④ 7-1/6” 5000# Double Ram and Spherical Annular
- ④ 4 stage diesel powered accumulator is compact skid mounted
- ④ Tested and inspected before every job by a 3rd party company
- ④ Available in multiple ram sizes

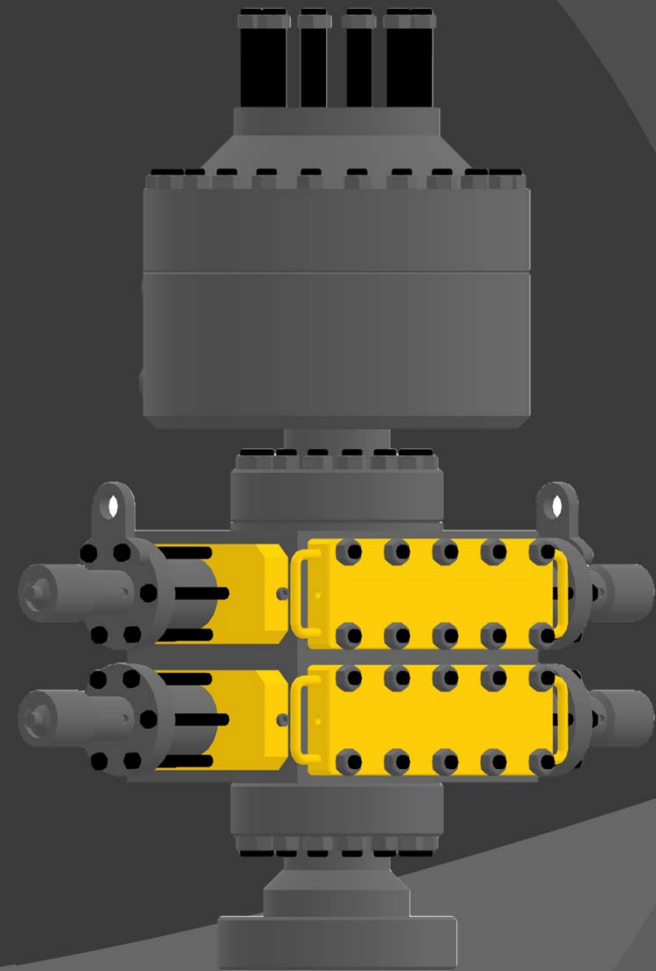

Benefits

- ⌚ Regularly certified to increase reliability
- ⌚ Eliminate sudden and uncontrollable release of oil, gas, and other fluids, posing significant safety and environmental risks
- ⌚ Prevent and control potentially hazardous situations during drilling and well completion activities
- ⌚ Spherical seals reliably on almost any shape or size kelly, drill pipe, tool joint, drill collar, casing or wireline
- ⌚ Compact design saves space



BOP Specs

Blow Out Preventer		
	7-1/16" 5K Hydraulic Double Ram BOP	7-1/16" 5K Hydraulic Spherical Annular
Rating	5,000 psi	5,000 psi
Length	66"	N/A
Width	25"	29"
Height	29"	31"
Weight	2,954 lbs.	3,063 lbs.
Open Fluid Vol.	.33 Gal	3.21 Gal
Closed Fluid Vol.	.35 Gal	4.57 Gal
Top Connections	7-1/16" 5K Studded	7-1/16" 5K Studded
Bottom Connections	7-1/16" 5K Studded	7-1/16" 5K Flange

Contact Information

To secure the highest quality of tools engineered, manufactured and tested in the USA contact your local WOS representative or contacts below

Main phone - 346-774-4433

Email - sales@wos.com

WOS Company Overview

- 🌀 Started Operations in Q3 2015
- 🌀 Fully Supported Downhole Tool Division
 - Design & Engineering
 - Machining & Fabrication
 - Field Operations
 - Rebuild & Redress
 - Evaluate Performance
- 🌀 Wireline
 - 4 trucks in the Northeast and 2 in West Texas
 - Started operations in July 2018
- 🌀 Operational Coverage
 - Pennsylvania, Ohio, West Virginia, and New York
 - Texas, New Mexico
 - North Dakota, Wyoming
 - Louisiana



WOS Locations

